

An Energy-Aware Clustering Approach for Ad-Hoc Sensor Networks

¹Venkateswarulu Naik B., ²Dr. S. Rama Krishna

¹JJTU Scholar, Jhunjhunu, Rajasthan, India

²Principal, SVIT, Secunderabad, Telangana, India

ABSTRACT

An Energy aware Clustering work has different approaches to routing protocol designs that achieve energy efficiency in an Ad-hoc Sensor network. Several of these works involve variations of mote-to-mote routing (flat routing) while some make use of leader nodes in clusters to perform routing (hierarchical routing). A key question then arises as to how the performance of an energy-aware, flat routing protocol compare with that of one based on hierarchical routing. This paper demonstrates a hierarchical routing protocol design that can conserve significant energy in its setup phase as well as during its steady state data dissemination phase. This paper describes the design of this protocol and evaluates its performance against existing energy-aware flat routing protocols. Simulation results show that it exhibits competitive performance against the flat routing protocols.

Keywords : Energy-Aware, Clustering, Ad-Hoc Sensor Network, Energy Efficiency.

I. INTRODUCTION

Ad-Hoc Sensor network comprise of stationary or mobile devices that communicate over wireless channels without any fixed wired backbone infrastructure. A sensor network is a special class of ad hoc sensor network that integrates sensing, processing and communications in small, battery-powered motes . These motes typically collaborate on a global sensing task and deliver required data to one or more hubs. Sensor nodes that have variable-powered RF transceivers can provide greater routing performance at the cost of higher power consumption. On the other hand, nodes that have fixed-power RF transceivers are generally cheaper but may be more prone to communication disruptions . Despite advances in Micro-Electro Mechanical Systems technology, energy constraints continue to limit the operations lifetime of a WSN and new, energy-aware motes are still experimental. Some SNs adopt a hierarchical configuration during deployment. The deployed network topology consists of distributed clusters of sensor nodes. Each of these clusters is managed by a cluster head, that is responsible for data aggregation within the cluster and communications between this cluster and neighboring ones. Within a SN, whether clustered or non-clustered, the primary means of relaying data among nodes is via a routing protocol. Hence, an essential and critical design requirement of the routing protocol is that it be energy-

aware. An energy-aware routing protocol should exhibit energy efficiency and balanced energy consumption across the SN. The first requirement ensures that the SN can sustain operations over prolonged, unattended periods. The latter requirement ensures that sections of the WSN do not fail prematurely and disrupt operations. A routing protocol for SNs typically comprises the three phases: set-up phase, route, management phase and data dissemination phase. With clustered wireless sensor networks, the set-up phase may also incorporate the formation of clusters around each available cluster head. Energy-aware routing protocols cannot merely deliver the message to a hub via the shortest or most energy-efficient route. Due to high usage, energy resources of nodes along these routes will be depleted faster than others and these routes will fail. Protocol design must also ensure that packet traffic is distributed relatively uniformly across the network so that energy resources of all nodes are depleted at a balanced rate. This will ensure that certain network sections/nodes will not be abruptly disconnected due to low energy resources . These are by no means trivial requirements and pose conflicting demands on the design of energy-aware routing protocols [20]. While conventional routing protocols for wireless networks are typically concerned with throughput and network latency, energy-aware routing protocols in SNs have to consider energy consumption, energy variance and scalability as well. With these issues in mind, we propose an energy-aware

routing protocol, Energy Clustering Protocol that routes messages via cluster heads. Unlike other clustered configurations, ECP exploits nodes at the boundaries of the cluster (border nodes) to assist in the forwarding of packets as well as to reduce dependency on and energy expenditure of cluster heads. Via performance simulations against existing energy-efficient routing protocols that use energy-distance metrics, probabilistic distribution of packet traffic and MAC adaptations, we show that ECP exhibits very low energy variance as well as high energy efficiency over WSNs with increasing number of nodes. The remainder of this paper is organized. surveys three existing energy efficient routing protocols proposed for multi-hop SNs. Highlights our motivation and the contribution of our work. Describes the detailed design of our proposed routing protocol. Simulation results.

II. Related Work

We discuss three more recently proposed routing protocols for multi-hop WSNs. They are Energy Probabilistic Routing , Gradient Based Routing Efficient and Reliable Routing .These routing protocols are similar in the sense that they make use of neighborhood information such as hop-count and node energy levels to relay data. They differ in their approach to distribute packet traffic.

2.1. Reactive protocol that is destination-driven.

That is, the hub or sink node initiates the route request and subsequently maintains the route . Selects routes probabilistically based on residual energy and energy consumption, thus helping to spread energy use among all the nodes. The protocol has three phases: setup, data dissemination and route maintenance. In the setup phase, interest propagation occurs as localized flooding, in the direction of the source node, to find all routes from source to hub and their energy costs. Before sending the request, the hub sets a “Cost” field to zero. Every intermediate node forwards the request only to neighboring nodes that are closer to the source node than itself and farther away from the hub. On receiving the request at a node, the energy cost for the neighbor that sent the request is computed and is added to the total cost of the path. Routing tables are generated during this phase. Only neighboring nodes with paths of

low cost are added to the routing table. Paths that have a very high cost are discarded. A probability is assigned to each of the neighbors in the routing table with the probability inversely proportional to the cost. In the data dissemination phase, data is relayed using information from the routing tables generated in the setup phase. Paths are chosen probabilistically according to the energy costs that were calculated earlier. This is continued till the data packet reaches the destination node. A node may therefore have multiple routes to the hub. In the route maintenance phase, localized flooding is performed intermittently from hub to source to keep all the paths alive.

III. Motivation and Contribution

These protocols in our survey use different approaches to achieve energy efficiency. A minimum cost spanning tree such as that used in EAR allows for a low total energy consumption but sacrifices node survivability by over-utilizing nodes on optimal routes. Probabilistic routing over multiple alternative paths to the hub is a technique used by EPR to overcome the over-utilization of nodes on shortest paths. Such multi-paths are built based on a weighted combination of neighboring node distance, projected energy expenditure and node residual energy. Energy availability metrics such as those employed in GBR control routing through nodes with the highest residual energy to balance energy consumption over the network. In all cases, the focus is primarily on balancing energy consumption during the data dissemination phase. Typically, the set-up phase in these protocols involves flooding that starts from the hub to relay location and route information throughout the SN. This technique consumes a significant proportion of energy from all nodes in the SN. Set-up tasks are important as they provide necessary network configuration and status information that allows subsequent successful operation of the WSN. In noisy environments and where the WSN nodes are mobile, initiating a secondary set-up phase is the most straightforward and practical way to re-configure the network and re-synchronize operations. In our design, we adopt a node clustering approach to utilize the gains of data fusion in tandem with energy conservation. Our proposed protocol, ECP, is designed with the following advantages: energy-efficient set-up process, low and balanced energy consumption during data dissemination

by utilizing cluster boundary nodes instead of solely cluster heads, and scalable performance.

IV. Energy Clustering Protocol Design

The design and operation of ECP is a routing protocol that minimizes route setup energy whilst maintaining low data dissemination energy consumption. A low energy route setup cost is important in applications where the network configuration may change dynamically due to inconsistent RF links, node mobility or simply when the nodes have fallen in residual energy after a period of time. In these applications, a low route setup cost is valuable to establish new routes again that reflect the new network topology in terms of residual energy and connectivity. Unlike LEACH [19], ECP does not assume that all network nodes are able to reach the hub directly. Nodes route data packets to cluster heads. Each cluster head then routes to its border nodes and these in turn route to border nodes and cluster head of a neighboring cluster. In this way, data is relayed from cluster to cluster and eventually to the hub. ECP is thus able to cater to larger network deployments where nodes may be scattered over significant distances. Also, the use of border nodes as routing support balances the energy consumption per cluster and obviates requirements for differentiated high transmission power cluster heads. Another novel feature of ECP is that cluster heads are elected probabilistically. ECP elects one hop clusters in a 3-round process, each round with increasing probabilities to form its clusters. This clustering process strives to increase the number of border nodes between clusters for the conduct of inter-cluster routing. Instead of using multiple hop clusters in a multi-hierarchical setting, ECP forms one-hop clusters in a single level hierarchy in the WSN. The advantages of one hop cluster are detailed in Subsection 4.2. In ECP, nodes already in a cluster may join another cluster if through distance estimation they are detected to be nearer to the other cluster head. Thus, more energy can be conserved through this simple scheme without additional control messages. Energy is also minimized during routing since nodes are clustered based on their distance from the cluster head. ECP does not need location information of its nodes through localization or GPS techniques as in the BCDP protocol [26]. The use of localization or GPS techniques consumes additional energy in order to initialize the nodes with their geographical coordinates.

ECP also does not require all nodes to send their information to the hub first for some centralized processing. Sending information to the hub for centralized processing is a common technique.

Clustering

Phase one of is to cluster sensor nodes together to achieve a maximum number of border nodes and minimum number of clusters. To prevent the same border nodes from being used continuously, the clustering algorithm aims to achieve denser clusters. One-hop clustering is adopted for ECP because these clusters have been shown to be more robust and subjected to less connectivity problems and communication overheads. When a node is first powered on, it will decide if it will elect itself to be a CH. The probabilities used for the 3-round clustering are the first, second and third rounds of clustering, respectively. These values are determined empirically. The flowchart in Figure 1 shows how cluster formation is done. CHs once elected wait for a random amount of time before broadcasting a PROBE message to its neighbors. The node is confirmed as a CH after the PROBE message is sent. This PROBE message announces the status of the newly formed CH to surrounding nodes. Nodes already elected to be CHs but have not yet sent the PROBE will give up their status to become cluster members. Nodes without cluster status (not cluster head or cluster members) will join the cluster as members via the PROBE message. The selection of a random range of time to wait before broadcasting a PROBE message is dependent on the density of the cluster and the maximum time for a message to be sent from one hop to the next. Let the cluster density d be defined as the number of nodes which a particular sensor node is able to reach within its transmission range. Let t be the maximum time taken for a PROBE or REPLY message to traverse one hop. This is also the minimum time that an elected cluster head node has to wait before broadcasting the PROBE message. Assuming a worst case scenario where all the $(d+1)$ nodes in a potential cluster (1 potential cluster head node surrounded by d neighbors) may be elected as cluster heads. To prevent this scenario, the minimum range of waiting time allocated to the nodes has to be at least $(d+1)t$. That is, a node that has elected itself as cluster head waits at least t units or as long as $(d+2)t$ units as shown in the right

diagram of Figure 1. After a node elects itself as a potential cluster head and broadcasts the PROBE message, only one CH is formed and the rest of the elected CHs give up their CH candidacy to be cluster members. Upon reception of a PROBE message, nodes without a CH will reply with a REPLY message and store the address of the CH. Nodes which have already joined a CH will also reply with a REPLY message if the PROBE message is from another CH. These nodes then compare the distance between the original CH and the PROBE message from the new CH and join the CH that is nearer. Its previous CH will be regarded as a secondary CH. This ensures that no CHs will be deprived of cluster members or some CHs will have too many cluster members. All CHs thus keep a record of their cluster members using the REPLY messages.

Cluster Status diagram

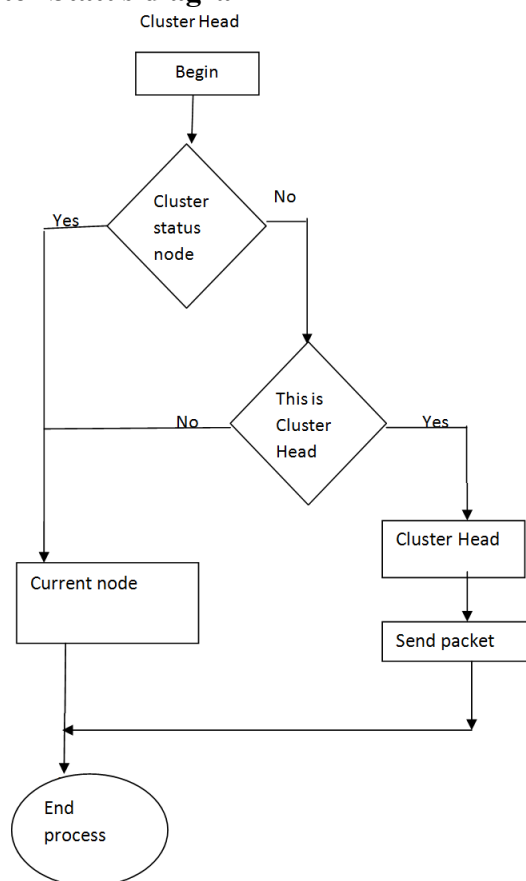

The route management phase comprises of route propagation and route request. Route propagation avoids conventional flooding to discover an unknown network. It achieves this by using the clusters from the previous phase, to forward the route messages. ECP forms a minimum energy-cost spanning tree of CHs instead of all nodes. CHs, upon receiving a routing cost, will be

able to update their cluster members of the route cost by intra-cluster broadcasting. The non-border node cluster members thus play a passive role in route dissemination. This helps to save transmission cost as not all nodes will have to participate in forwarding the route messages. A route request round follows after route propagation. This is necessary because of the possible presence of isolated clusters. An isolated cluster that does not have any border nodes with another cluster misses out on route information. This phase of ECP discovers these nodes without a routing table and requests for a route.

Route Propagation Route propagation begins when the hub first broadcasts an advertisement (ADV) packet with its address to its neighbors'. All nodes start with an original cost to the hub of infinity. The ADV packet from the hub starts with a cost of 0. Nodes that receive the ADV packet add the cost of the ADV and the cost of transmitting from sender to receiver. If this cost is smaller than the receiver's original cost, it will add the sender's information into its route table. Otherwise, the ADV packet is ignored. Where the sender is the hub, the node will add the route to the hub and forwards future data packets direct to the hub and not to its CH. Nodes receiving the ADV packet from a non-hub node will send it to their CHs. In the case of border nodes where they have more than one cluster head (one primary CH where it sends its data packet to and secondary CHs for routing purposes), the border node sends point-to-point traffic to all its primary and secondary CHs. The CHs upon receiving the ADV will check that the cost of this ADV is lower than its original cost. If the ADV packet is of a lower cost, it will broadcast this route cost to its cluster member nodes. Border nodes upon receiving this new routing cost will thus be able to resend it to the other CHs. Figure 2 shows this.

Diagram: HUB Broad cost Network

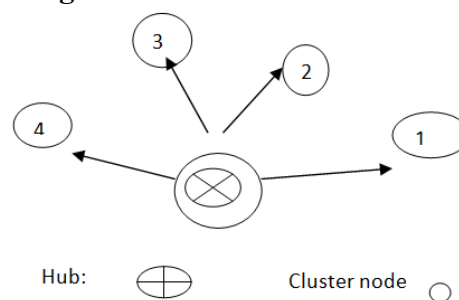

Route Request (Route propagation) Route request starts after route propagation of ADV packets. Here, nodes that do not have a route after a timeout period potentially belong to an isolated cluster that does not have a border node with other clusters. These nodes then broadcast Route Request messages (RREQ) in an attempt to discover a neighboring cluster that has a route to the hub. When nodes receive an RREQ packet, they will reply with an ADV packet. The sender of the RREQ packet receives this ADV and propagates the route information to its own CH. The CH then continues with the normal route propagation. CHs and non-CHs may broadcast RREQ packets and the lowest route cost ADV packet is kept. Transmission of data packets start immediately after a route to hub is received. If a lower cost ADV should arrive to the node, dynamic updating of the lower cost route is done concurrently with application sensing. The lower cost route will thus be the new route used.

Energy Metric The energy metric that is used can include information about the cost of using the path, energy status of the nodes along the path or reliability of the RF links etc. ECP evaluates routes by evaluating the energy used to transmit and receive on a link. For motes with variable transmission power, the energy metric would be a function of the distance between the sender and receiver. For motes with fixed transmission power, the energy to transmit and receive on a link is the same for all nodes. As channel acquisition overhead is large, small control packets have disproportionately high energy costs. ECP minimizes the use of control packets to propagate the route information to all the nodes by propagating the route information to its CHs instead.

Energy Model In the evaluation of the protocols in this study, the energy model in [19,28] is used. The energy costs of broadcast, point-to-point and non-destination traffic are different. We denote the energy lost due to channel transmission as r^2 , where r is the distance between the sending and receiving nodes. Therefore, the energy expended to transmit a k -bit packet over a distance d and to receive that packet defined by: $E_{tx}(k, d) = E_{elec} * k + E_{amp} * k * d^2 + b$ (1) $E_{rx}(k) = E_{elec} * k + b$ (2) where, E_{tx} = Energy taken to transmit the packet E_{rx} = Energy taken to receive the packet E_{elec} = Energy dissipation of radio transceiver circuitry E_{amp} = Energy to run transmit amplifier For simplification, we consider the radio channel to be symmetrical. The above energy

model where a node consumes energy through transmitting/receiving packets may be described as a linear equation [29]. To account for energy consumption at the data link layer through device mode changes and channel acquisition cost, a fixed cost b is included that depends on the operation mode: Broadcast traffic: In an IEEE 802.11 Broadcast, the sender listens briefly to the channel and sends the messages if the channel is clear. We define the fixed channel access cost as bb -send and bb -recv: $E_{tx}(k, d) = E_{elec} * k + E_{amp} * k * d^2 + bb$ -send $E_{rx}(k) = E_{elec} * k + bb$ -recv Point-to-point traffic: In IEEE 802.11, when a node sends an RTS control message identifying the receiver node, the latter responds with a CTS. Upon receiving the CTS, the data is sent and the sender waits for an ACK from the receiver. This handshake overhead is accounted by the fixed channel access cost for sending/receiving a packet as bop -send and bpp -recv respectively: $E_{tx}(k, d) = E_{elec} * k + E_{amp} * k * d^2 + bop$ -send $E_{rx}(k) = E_{elec} * k + bpp$ -recv Non-destination traffic: Non-destination nodes in the range of either the sender or receiver overhear some or all of the packet traffic. Non-destination nodes in non-promiscuous mode can enter into a reduced energy consumption mode while data is being transmitted in the vicinity. For non-promiscuous nodes discarding traffic, Equation (2) becomes: Discard cost = $E_{elec} * k + discard$ (3) Experimental values for all the b parameter in the 3 modes of operation are listed as follows: Operation bb -send bb -recv bop -send bpp -recv discards $b(up)$ 266 56 454 356 24 4.4. **Data Dissemination** The clustering phase, route propagation and route request processes ensure that every node has a route to the hub via its own CH. Depending on the application, nodes will start generating DATA packets at periodic intervals or cluster member nodes may go into sleep mode if they are not needed. If a node has a direct route to the hub, the DATA packet will be sent direct to it. Cluster member nodes that are not border nodes will send the DATA packet to its CH for data fusion. Besides cluster members, CHs also keep a record of member nodes that are border nodes and their corresponding costs to the hub. The CHs will select the border node with the least cost to the hub and route the DATA packet to the border node. Border nodes upon receiving a DATA packet will send the packet to its record of CHs with lower energy cost than itself. Hence, DATA packets are routed from cluster to cluster till it reaches the hub. Data aggregation is also used by ECP. When

DATA packets meet along the same path at a CH, the data is aggregated before transmission. Through this inter-cluster routing approach using CHs and border nodes together with data fusion and aggregation methods, the network is effectively condensed into a shortest spanning tree of CHs and their border nodes. Non-border node cluster members thus do not participate in the routing decisions. The total number of transmissions is thus reduced leading to higher energy savings and lower variance across the network.

V. Simulation

A Discrete-event simulator designed for wireless networks. It is made up of library modules, each of which simulates a specific routing protocol in the protocol stack. Simulator settings used are shown in Table 1.

5.1. Performance Metrics The following metrics were used to measure the performance of the routing protocols. Packet delivery ratio (PDR): this measures the percentage of data packets generated by the nodes that are successfully routed to the hubs. It is expressed as: $\%100 \times \frac{\text{Total data of number sent packets}}{\text{Total data of number packets delivered}}$ successful Packet latency: this measures the average time it takes to route a data packet from the source node to the hub. It is expressed as: $\frac{\text{Total data of number packets delivered}}{\text{Individual data packet latency}}$ Energy Consumption: this measures the energy expended per delivered data packet. It is expressed as: $\frac{\text{Total data of number packets delivered}}{\text{Energy Consumption}}$

Noisy Environment Tests

These tests analyze the protocols' behavioral differences in an actual operating environment. The test is conducted by generating random noise factors of between 10% and 50%. The noise factor of a node indicates the probability that packets received by the node are corrupted or lost in transmission. Results were averaged over 30 runs each with a different .

VI. CONCLUSION

This research has demonstrated that ECP is a viable energy conserving protocol which balances energy consumption over the network. Simulation results have shown that the performance of ECP is scalable for

networks as large as 400 nodes. ECP has made use of a clustering approach to reduce the number of packets sent through the network significantly, thus reducing communications costs across the network. The 3-round one-hop clustering technique of ECP lets nodes join the nearest CH without incurring excessive energy control costs leading to an energy-efficient setup. The route setup cost of ECP is shown to be lower than existing protocols, allowing new clusters to be formed inexpensively once the nodes fall in residual energy. Without assuming geographical knowledge of nodes, ECP is able route data packets reliably to the hub. Inter-cluster routing has also good scalability and is shown to be a more energy-efficient method of propagating route information to a large number of nodes compared to non-clustered WSNs. Energy efficiency of ECP outperforms the protocols of EAR, EPR and GBR without compromising packet delivery ratio, latency and energy variance. Future work could include research into improving performance in light to moderate traffic scenarios with multi-hubs, an intracluster protocol, reducing inter-cluster interference and the election of uniformly distributed cluster heads.

VII. REFERENCES

- [1]. T. Kauri, J. Beak, "A Strategic Deployment and Cluster-Header Selection for Wireless Sensor Networks," *IEEE Transactions on Consumer Electronics*, Vol. 55, 4, pp. 1890-1897, (2009).
- [2]. I. Gupta, D. Riordan, and S. Sample, "Cluster-head election using fuzzy logic for Wireless Sensor Networks," In *Communication Networks and Services Research Conference, Proceedings of the 3rd Annual*, pp. 255-260, 2005.
- [3]. G. Ran, H. Zhang, S. Gong, "Improving on LEACH protocol of Wireless Sensor Networks Using Fuzzy Logic," *Journal of Information & Computational Science*, pp. 767-775, 2010.
- [4]. N. Bazaar Torghabeh, M. R. Akbarzadeh Totonchi, and M. H. Yaghmaee Moghaddam, "Cluster Head Selection using a Two-Level Fuzzy Logic in Wireless Sensor Networks," *International Conference on Computer Engineering and Technology*, pp. 357-361, 2010.
- [5]. M. C. M. Then, T. Then, "An Energy Efficient Cluster-Head Selection for Wireless Sensor Networks," *International Conference on Intelligent*

- Systems, Modeling and Simulation, pp. 287-291, (2010).
- [6]. S. Bandyopadhyay and E. J. Coyle, "An energy efficient hierarchical clustering algorithm for wireless sensor networks," in Proceeding of IEEE INFOCOM, vol. 3, pp. 1713-1723, (2003).
- [7]. J. M. Kim, S.H. Park, Y.J. Han, and T.M. Chung, "CHEF: cluster head election mechanism using fuzzy logic in Wireless Sensor Networks," International Conference of Advanced Communication Technology, pp. 654–659, 2008.
- [8]. O. Youngish, M. Runs, and S. Ramasubramanian, "Node Clustering in Wireless Sensor Networks: Recent Developments and Deployment Challenges," IEEE Network, vol. 20, 3, pp. 20-25, (2006).
- [9]. W. B. Heinemann, A. P. Chandrakasan, and H. Balakrishnan, "Energy-Efficient Communication Protocol for Wireless Micro sensor Networks," Proceeding of the Hawaii International Conference on System Sciences, pp. 1-10, (2000).
- [10]. L. A. Sade, "Fuzzy Sets," Information and Control, vol. 8, 3, pp. 338-353, (1965).
- [11]. L. A. Zane, "Outline of a New Approach to the Analysis of Complex Systems and Decision Processes," IEEE Transactions on Systems, Man and Cybernetics, SMC-3, 1, pp. 28-44, (1973).
- [12]. J. Greene, J. Rabies, "Lightweight Time Synchronization for Sensor Networks," International Workshop on Wireless Sensor Networks and Applications, (2003).
- [13]. S. Singh, Miwok, and C. Raghavendra, "Power-aware routing in mobile ad hoc networks," in Proceeding of 4th Annual ACM/IEEE International Conference on Mobile Computing Networking (Modicum), (1998).
- [14]. E.H. Madman, and S. Assyrian, An experiment in linguistic synthesis with a fuzzy logic controller. International Journal of Man-Machine Studies, vol. 7, 1, pp. 1-13, (1975).
- [15]. N. Bouabdallah, M. E. River–Angeles, and B. Sericola, "Continuous Monitoring Using Event-Driven Reporting for Cluster-Based Wireless Sensor Networks," IEEE Transactions on Vehicular Technology., vol. 58, no. 7, pp. 3460-3479, (2009).
- [16]. X. Zhu, L. Shan, and T. P. Yum, "Hausdorff Clustering and Minimum Energy Routing for Wireless Sensor Networks," IEEE Transactions on Vehicular Technology, vol. 58, 2, pp. 990-997, (2009).
- [17]. S. Sore, W. Heinemann, "Cluster head election techniques for coverage preservation in wireless sensor networks", Ad Hoc Networks, vol. 7, no. 5, pp. 955-972, (2009).
- [18]. W. B. Heinemann, A. P. Chandrakasan, and H. Balakrishnan, "Energy-Efficient Communication Protocol for Wireless Micro sensor Networks," Proceeding of the Hawaii International Conference on System Sciences, pp. 1-10, (2000).
- [19]. L. A. Zane, "Fuzzy Sets," Information and Control, vol. 8, 3, pp. 338-353, (1965).
- [20]. L. A. Sade, "Outline of a New Approach to the Analysis of Complex Systems and Decision Processes," IEEE Transactions on Systems, Man and Cybernetics, SMC-3, 1, pp. 28-44, (1973).
- [21]. J. Greened, J. Rabies, "Lightweight Time Synchronization for Sensor Networks," International Workshop on Wireless Sensor Networks and Applications, (2003).
- [22]. S. Singh, Miwok, and C. Raghavendra, "Power-aware routing in mobile ad hoc networks," in Proceeding of 4th Annual ACM/IEEE International Conference on Mobile Computing Networking (Modicum), (1998).
- [23]. Caching, Howe, Willie, M.Gerla, (1997), "Routing in clustered multichip mobile wireless networks with fading channel", in Proceeding of IEEE Singapore International Conference on Networks (SICON ,07), Pages 197- 211.
- [24]. V.Rodoplu, T.H.Meng, (1999), "Minimum energy mobile wireless networks", IEEE Journal on Selected Areas in Communications, Volume 17, Number 8, Pages 33-44.
- [25]. R.Wattenhofer, Lela, P.Bahl, Y.M.Wang, (2001), "Distributed topology control for power efficient operation in multichip ado networks", IEEE Magazine, Volume 3.
- [26]. S.R.Gandham, M.Dawande, R.Prakash, S.Venkatesan, (2003), "Energy efficient schemes for wireless sensor networks with multiple mobile base stations", in Proceedings of IEEE Global Telecommunications Conference, Pages 377-381.
- [27]. D.Ganesan, R.Govindan, S.Shenker, Diestrum, (2001), "Wireless sensor networks", ACM Mobile

Computing and Communications Review, Volume 5, Number 4.

- [28]. S.K.Singh, M.P.Singh, D.K.Singh, (2010), "A survey of energy efficient hierarchical cluster based routing in wireless sensor networks", International Journal of Advanced Networking and Application, Volume 2, Issue 2, Pages 570–580.
- [29]. Ming Liu, Japanning Cao, Guitar Chen, Xiaoping Wang, (2009), "An energy aware routing protocol in wireless sensor networks", Sensors 2009, Volume 9, Pages 445-462.
- [30]. Jamal Karaka, A.E.Kamal, (2004), "Routing techniques in wireless sensor networks: a survey", IEEE Communications.