



Automation of Weather Station in Agricultural Zone

Prof. Amar Banmare, Nikita Ambulkar, Dhanshree Girhe, Pratiksha Haware, Minakshi Lavale

ABSTRACT

Weather monitoring plays an important role in human life, so the collection of information about the temporal dynamics of weather changes is very important. In any industry during certain hazards it is very important to monitor weather. The fundamental aim of this paper is to develop an embedded system to design a weather monitoring system which enables the monitoring of weather parameters in an industry. Such a system contains pair of sensors like temperature, Gas and humidity will be monitored and LPC1768 microcontroller (ARM9). The data from the sensors are collected by the microcontroller and also microcontroller sends the sensors data in to the LABVIEW by using the Serial Communication and this module will keep the data in excel page & also we can get the SMS in the mobile with the help of GSM module. The system uses a compact circuitry built around LPC1768 (ARM9) microcontroller Programs are developed in Embedded C using the IDE Keiluvision4. JTAG is used for loading programs into Microcontroller.

Keywords: ATMEGA 16, Humidity sensor, Temperature Sensor, LABVIEW, GSM Module

I. INTRODUCTION

An automated weather station is an instrument that measures and records meteorological parameters using sensors without intervention of humans. The measured parameters can be stored in a built-in data logger or can be transmitted to a remote location via a communication link. If the data is stored in a data logger, recorded data must be physically downloaded to a computer at a later time for further processing. Therefore, the communication system is an essential element in an automated weather station. Today, automated weather stations are available as commercial products with variety of facilities and options. Although automated weather stations can be built and implemented in remote parts of Sri Lanka to bring down the cost of maintaining weather

stations, until recently, not much emphasis has been given for building and using such instruments locally. Automated weather stations have been developed in universities by interfacing meteorological parameter monitoring sensors to microcomputer/commercially available data loggers with communication devices or through serial and parallel ports to obtain hard copies of weather data. Recently, the University of Colombo developed an automated weather station with USB communication facility and a built-in data logging facility. The system used wired communication to transfer data to the monitoring station through the computer's built-in USB interface. The present work is a further extension of the earlier developments. The main objective of this work is to develop a standalone modular weather

station with a remote communication facility to capture and transmit meteorological parameters.

Remotely monitoring of environmental parameters is important in various applications and industrial processes. In earlier period weather monitoring systems are generally based on mechanical, electromechanical instruments which suffer from the drawbacks like poor rigidity, need of human intervention, associated parallax errors and durability. Kang and Park have developed monitoring systems, using sensors for indoor climate and environment based on the parameters mentioned in 2000. Combination of these sensors with data acquisition system has proved to be a better approach for temperature and relative humidity monitoring in 2005. Lasso in 1993 introduces the usage of surface acoustic wave's devices as temperature sensor. This demand the development of a microcontroller based embedded system for weather monitoring. Such a system should monitor and provide data for remote examine. The collected data by weather monitoring system can easily be exported to a PC via a serial port to make subsequent data analysis or graphic and digital storage thus automatic data collection is possible without giving up PC resources.

II. EXISTING & PROPOSED SYSTEM

In the previous research, a single master-multi slave microcontroller communication method has been developed. The microcontroller is able to communicate using unicast communication, i.e. the master gave orders to one slave address via the master-slave network that has star topology. Then the slave who has the same address which is requested will respond or take action in accordance with the master command. Modbus

Protocol is the rules of data communication with the master-slave technique. In these communications there is only one master and one or several slave which form a network. Master only do one communication at a time. Slave will only communicate if there is a command (query) from the Master and cannot communicate with another slave. Addressing modes used by the Modbus there are 2, i.e., unicast and broadcast.

The design and implementation of weather monitoring & controlling system is the model with the ability to perform data acquisition on temperature, gas, humidity and accelerometer sensors attached. And it can give these sensors data to ADC Port of LPC1768. It can also upload the data continuously to excel sheet in LABVIEW with the help of RS232 Cable and also receives SMS with the help of GSM.

III. BLOCK DIAGRAM

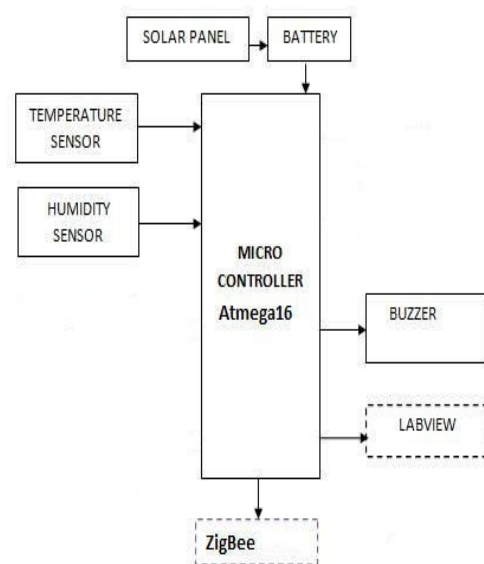
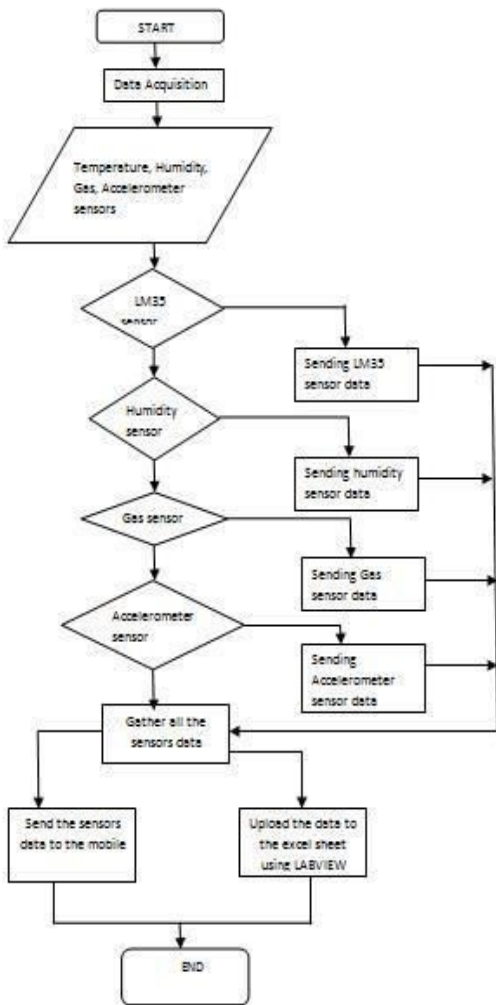

Figure 1. Block Diagram

4.1 Flowchart



Hardware

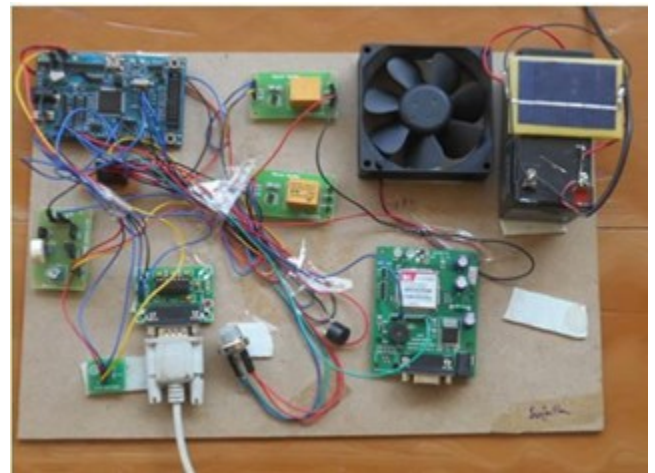

Figure 6

In this project, we have to acquire all the environmental parameters like temperature, humidity, gas and accelerometer sensors and the measure these sensor values using ADC pins in LPC1768. Here in the above figure we use Multi sensor Board for placing the sensors, and accelerometer sensor for checking the earthquake condition. And for the power supply I'm using the 12v battery. Max Board is used for transmitting the data using serial communication. And also these sensor values will be displayed wirelessly on a Mobile using GSM Module.

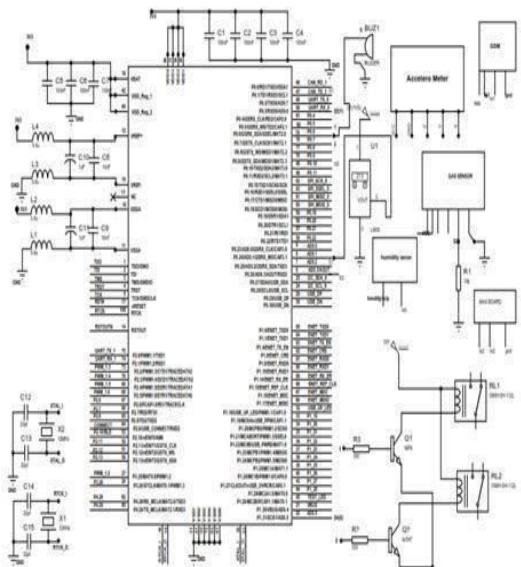

Figure 5. proteus output

The data transmitting from the hardware can be received in Lab view using the serial communication. The read string displays the transmitted data. And here Different sensors & those corresponding values are displayed with the indications like Metering etc., And in the Lab view itself we create a Excel File And Place the excel file in that folder because the updating or value changes can also seen in the excel file like shown below.

2. Security purpose.

VI. CONCLUSION

This paper demonstrates Design and Implementation of Weather Monitoring & Controlling System used for controlling the devices as well as monitoring the environmental parameters. Embedded controlled sensor networks have proven themselves to be a reliable solution in providing remote control and sensing for environmental monitoring systems. The sensors have been integrated with the system to monitor and compute the level of existence of Accelerometer, gas, temperature and humidity in atmosphere using information and communication technologies. The sensors can upload the data in Lab view using serial Communication.

VII. FUTURE SCOPE

Adding of more sensors to monitor other environmental parameters such as Soil PH Sensor, CO2 and oxygen Sensor while allowing the replacing of current sensors if a wider range of measurements is desired. And also Integration of additional monitoring devices such as a Wi-Fi camera to monitor growth of agricultural product. And also the data can be uploaded to web server continuously.

VIII. REFERENCES

[1]. Kang. J. and Park S. "Integrated comfort sensing system on indoor climate" Sensors and Actuators. 2000. 302-307.

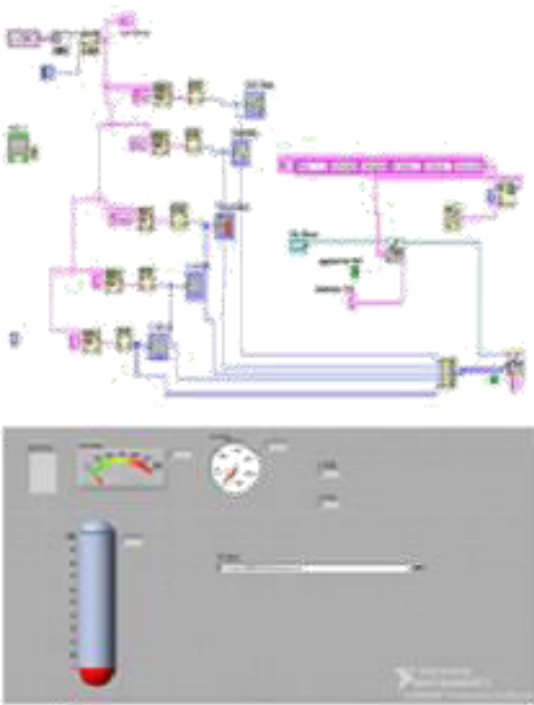

Figure 7

	Humidity	Temperature	X Value	Y Value	Time and Date
1	39	36	39	3482	3482
2	42	39	39	3483	3488
3	42	35	39	3484	3486
4	42	35	39	3484	3486
5	42	36	39	3482	3487
6	42	35	40	3482	3486
7	42	32	39	3482	3486
8	39	204	38	3482	3487
9	42	37	39	3482	3489
10	42	39	38	3489	4/29/2018 18:22
11	42	39	38	3489	4/29/2018 18:22
12	42	35	39	3484	4/29/2018 18:22
13	42	35	39	3482	4/29/2018 18:22
14	34	35	39	3482	4/29/2018 18:22
15	42	38	40	3482	4/29/2018 18:22
16	42	38	40	3482	4/29/2018 18:22
17	42	39	39	3482	4/29/2018 18:22

Figure 8.. Lab VIEW Result

V. APPLICATIONS & ADVANTAGES

5.1 Applications

1. Used in coal mine, bio gas manufacturing centers.
2. Used in power plant generation.
3. Agriculture field monitoring.
4. Home automation.
5. Industrial purpose

5.2 Advantages

1. This project can be used to save power.

- [2]. Moghavvemi M. and Tan. S. “A reliable and economically feasible remote sensing system for temperature and relative humidity measurement”. *Sensors and Actuators*. 2005. 181-185.
- [3]. Campbell Scientific, Data loggers, Sensors and Weather stations, <http://www.campbellsci.co.uk>.
- [4]. Vaisala, Automatic weather stations, <http://www.vaisala.com/en/products>.
- [5]. Prodata, Affordable automatic weather stations, <http://www.weatherstations.co.uk>.
- [6]. Sparks L. & Sumner G., “Microcomputer Based Weather Station Monitoring System”, *Journal of Microcomputer Applications*, 7, pp. 233-24, 1984.
- [7]. Bagiorgas H.S, Margarita N. A, Patentalaki. A, Konofaos. N, Dmetrios P, Matthopoulos & Mihalakakou G., “The Design Installation and Operation of A Fully Computerised, Automatic Weather Station for High Quality Meteorological Measurements”, *Fresenius Environmental Bulletin*, 16–8, pp.948- 962. 2007.
- [8]. Guo X. & Song Y., “Design of Automatic Weather Station Based on GSM Module”, *Int. Conf. on Computer, Mechatronics, Control and Electronic Engineering*.
- [9]. Hettiarachchi H.A.P.K. & Fernando I.M.K., “USB Based High Speed Data Acquisition System for an Unmanned Weather Station”, *2nd Int. Conf. on e-governance*, 2004.
- [10]. Modicon Inc. Industrial Automation System, “Modicon Modbus Protocol Reference Guide-PI-MBUS-300”, Rev. J, June 1996, http://www.modbustools.com/PI_MBUS_300.pdf, Accessed June 1st, 2011.