



4th National Conference on Advances in Engineering and Applied Science
Organized by : Anjuman College of Engineering and Technology (ACET) Nagpur,
Maharashtra, India, In association with
International Journal of Scientific Research in Science and Technology



Performance Analysis of Single-Phase Inverter

Prof. R. C. Ujwane, Vijaya Barai, Akshay Katre, Ankit Burbande, Abhishek Borikar, Prashant Sarve

Dr. Babasaheb Ambedkar College of Engineering and Research, Nagpur, Maharashtra, India

ABSTRACT

This paper deals with the simulation and design of 1kw, 230 volt & 50 Hz inverter. The elementary purpose of this device is to transmute 12V DC to 230V AC. We design a low cost inverter circuit using MOSFET motivated by an growing demand due to frequent power shortage. The system is design with microcontroller (ATMEGA 328) for control circuit. A 5 volts regulator (IC 4047) is used to supply fix 5V for biasing the switching and amplifying circuitry. Pure sine wave inverter are demand of modern era whenever it comes to utilization of DC power sources for both low and high power application. These inverters not only increase the efficiency of power system but also prevent the electrical component from damaging. In recent time research has been carried out on producing cost effective and efficient pure sine wave inverter. And the design of the paper proposes highly useful for low power-based application. MATLAB/SIMULINK software is use for simulation & verification of proposed circuit of inverter. The main advantage of this inverter is providing backup up to 1kw load.

Keywords : Mosfet, Zener diode, Square Wave

I. INTRODUCTION

Inverters have taken a prominent role in the modern technological world due to the sudden rise of electric cars and renewable energy technologies. Inverters are used in power system to covert direct current (DC) power from batteries or PV arrays into alternating current (AC) power.

An inverter is a device that changes DC voltages into AC voltages. A direct current is a current that flows in only one direction, while an alternating current is that which flows in both positive and negative directions. Modern inverters use solid-state designs and microprocessor controls to produce high quality AC power very efficiently.

As the technology advances, the hydroelectric generations were developed, gas firing generating station, and weird tubing methods of generating power supply were developed. In spite of all these developments, there was still failure in electrical power generations as a result of obsolete equipment at the generating stations. The electrical inverter is a high-power electronic oscillator. It maintains a continuous supply of electric power to the connected loads or equipment's when the utility power is not available. Inverters are generally used in a host of applications that include variable speed drive, uninterruptible power supplies, flexible AC transmission system (FACTS), high voltage DC transmission systems (HVDC), active filters among the others. It is inserted between the source of power (typically commercially utility power) and the load is

protecting. The inverter performs the opposite function of a rectifier.

For alternative energy systems, inverters are the essential step between a battery's DC power and the AC power needed by standard household electrical systems.

In a grid connected home, an inverter/charger connected to a battery bank can provide an uninterruptible source of backup power in the event of power failures or can be used to sell extra alternative energy power back to the utility company. Batteries produce power in direct current can run at very low voltages but cannot be used to run most modern household appliances. Utility companies and generators produce sine wave alternating current (AC) power, which is used by most commonly available appliances today. Inverters take the DC power supplied by a storage battery bank and electronically convert it to AC power.

An inverter is a device that takes a direct current input and produces a sinusoidal alternating current output. An inverter needs to be designed to handle the requirements of an energy hungry household yet remain efficient during periods of low demand. The efficiency of inverter is highly dependent on the switching device, topology and switching frequency of the inverter. Alternating current (AC) power is used as a power source as well for transmission purpose because it can be generated and converted from one voltage to another. Transmission of AC power over long distance is still in use, however it results in relatively high transmission losses. The types of losses are transient stability problem and operational requirements such as dynamic damping of electrical system may also arise along the transmission line

II. LITERATURE SURVEY

2.1. Inverter

An electrical device that converts DC power into AC power at coveted yield voltage and frequency is called an Inverter. Phase controlled converters when worked in the inverter mode are called line commutated inverters. Be that as it may, line commutated inverters at the yield terminal requires a current AC supply which is utilized for their replacement. This implies line commutated inverters can't work as separated AC voltage sources with DC power. In this way, voltage level, frequency and waveform on the AC side of the line commutated inverters can't be changed. Then again, drive commutated inverters give an autonomous AC yield voltage of movable voltage and movable frequency and have accordingly much more extensive application.

Inverters can be comprehensively characterized into two sorts in view of their operation:

- Voltage Source Inverters (VSI)
- Current Source Inverters (CSI)

Voltage Source Inverters is one in which the DC source has little or immaterial impedance. At the end of the day VSI has firm DC voltage source at its information terminals. A present source inverter is bolstered with movable current from a DC wellspring of high impedance, i.e. from a firm DC current source. In a CSI encouraged with firm current source, yield current waves are not influenced by the load. From view purpose of associations of semiconductor gadgets, inverters are named under

- Bridge Inverters
- Series Inverters
- Parallel Inverters

2.2 Single Phase Half Bridge

It comprises of two semiconductor switches T1 and T2. These switches might be BJT, Thyristor, and IGBT and so on, with a recomense circuit. D1 and D2 are called Freewheeling diode as they criticism the load reactive power.

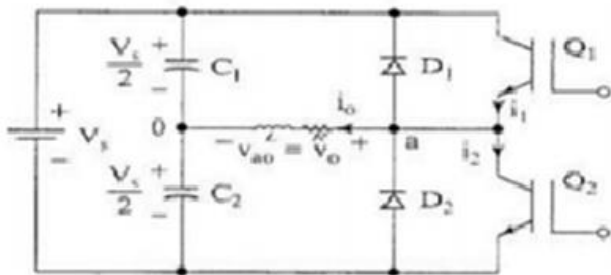

Figure 1. Circuit Diagram of Single-Phase Half Bridge Inverter

2.3 Full Bridge VSI Inverter

The S1-S4 are solid state component that can be used in inverter are transistor, IGBT, MOSFET or SCR.

When S1 and S2 are ON current flow from S1-Load-S2.

When S3 and S2 are ON current flow from S3-Load-S4.

This is the basic technique that produces a square AC. We all know the frequency of available power supply is 50Hz. This means that we need to turn the switch ON and OFF 100 times in a second. For this we have semiconductor switches such as MOSFET, they can turn ON and OFF several times with the help of control signals easily.

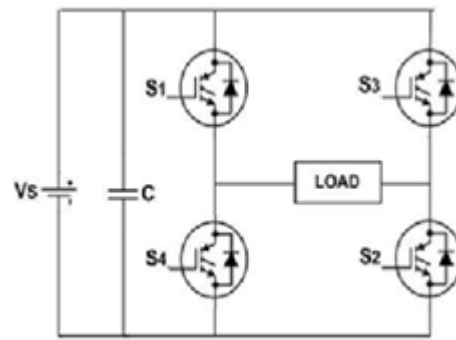

Figure 2. Circuit Diagram of Single-Phase Full Bridge Inverter

III. BLOCK DIAGRAM

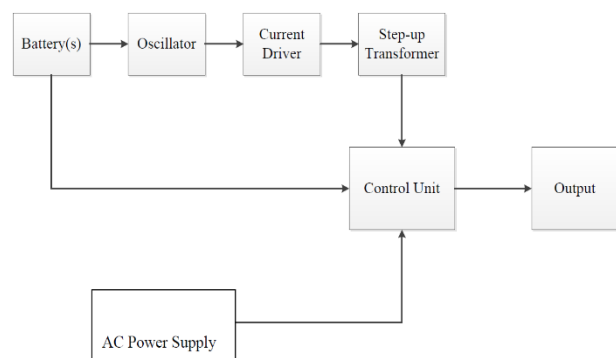

Figure 3. Block Diagram

IV. CIRCUIT DIAGRAM

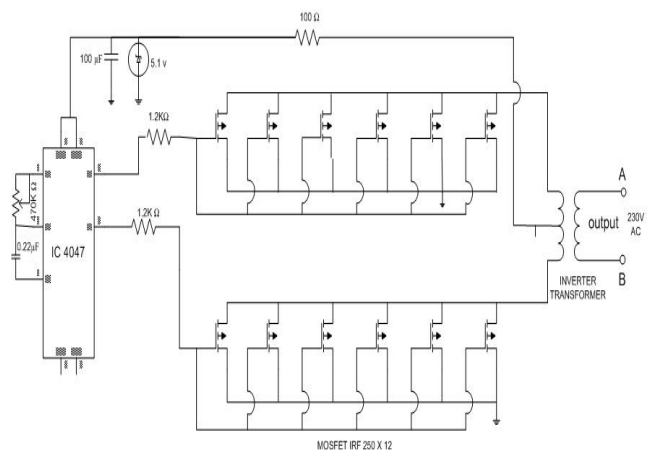

Figure 4. Circuit Diagram

V. SYSTEM SPECIFICATION

Inverter and switching devices specification are illustrated below;

INPUT VOLTAGE	12 VOLT (DC)
INPUT CURRENT	25 AMP
MAXIMUM OUTPUT POWER	1000 WATT
OUTPUT VOLTAGE	230 VOLT (AC)
OUTPUT CURRENT	4.34 A(AC)
INPUT FREQUENCY	NIL
OUTPUT FREQUENCY	50HZ

VI. DESIGN PROCESS

We had done both software simulation and hardware implementation of this inverter. Both are illustrated below

(1) Software simulation design

We have used MATLAB software for simulation of inverter circuit

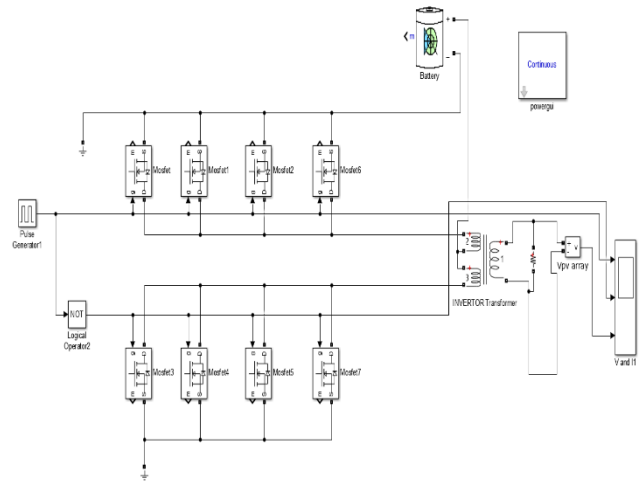

Figure 5. MATLAB Simulation design of proposed inverter circuit

(2) Hardware design

- 12-volt DC battery (for testing purpose we are using DC battery).
- Zener diode is used for regulating 5V for biasing the IC4047
- IC 4047 for the drive circuit and for generating and triggering switching pulse.
- 12 volt/230volt centre-tapped transformer for implementing the inverter.
- Microcontroller Arduino ATMEGA328 was used for charging the battery.

VII. OUTPUT WAVEFORM

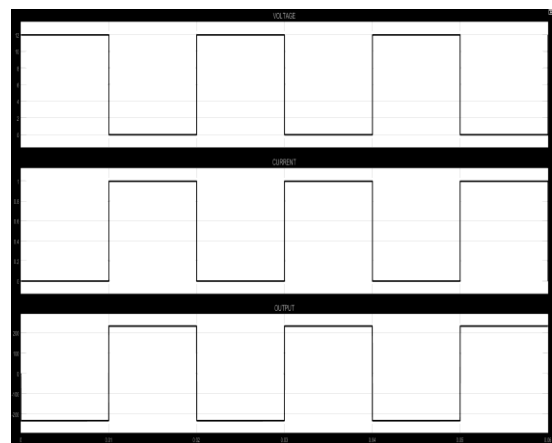

Figure 6. Final output for inverter pure AC signal

VIII. CONCLUSION

This paper discusses the simulation and hardware implementation of single-phase inverter. This paper has presented a single phase 230-volt 1000 W inverter. The main objective of this paper was to simulate the inverter circuit and fabricate the inverter. AC can't be stored for future use whereas DC can be stored in battery & it can be converted back to AC by using power inverters when require. It is optimal solution of converting AC to DC. The harmonics can be reduced by selecting the appropriate modulation indices. By increasing the levels, we can reduce harmonics in output voltage waveform.

IX. REFERENCES

- [1]. "Design Simulation & Fabrication of Inverter" by Shekhar Kumar Biswas and Puja Gupta.
- [2]. M. H. Rashid, Power Electronics Circuits Devices and Application.
- [3]. Application of Power electronics by Shingare
- [4]. "Design and Implementation of Cost-Effective Inverter" Niaz Morshedul Haque, Ifthekhar Ahammad, Sayem Miah, Asad Ahmed Miki, Hasan Ahmed
- [5]. Design and implementation of a single-phase inverter with sine wave tracking method for emergency power supply with high performance reference.
- [6]. Analysis of single-phase diode clamped three level inverters by Bharti Katre and Apurva Dabre.
- [7]. High Efficiency Single Phase Inverter design Didi Istradi, Basyir, Arif Juwito Febransyah.
- [8]. A Novel Single-Phase DC-AC Inverter by Muhammad Faizan Abdulla, Sahid Iqbal, Syafrudin Masri.
- [9]. Grid Connected Single Phase Multilevel Inverter, Mahmoud A. Sayed Maha G Elsheikh Mohmmadd Oberoi
- [10]. Design and Implimentation of Single-Phase Pure Sine Wave Inverter Using Multivibrator IC by Miraj Hasan, Junaid Maqsood Salman Ahmed.
- [11]. Single Phase 5 level Inverter with Less no. Of Power Elements for Grid Connections by Mohamed Orabi, Mahrous Ahmed, Mohamed Sayed
- [12]. Design And Simulation Of 5 Level Cascaded Multilevel Sinusoidal PWM Strategies by V.Manimala, Mrs. N.Geetha, Dr. P.Renuga