

Power Quality Improvement in Converters Using ANN

Govindasamy. S¹, Vallarasu. N², Bharathi Raja. C², Karmegam.S², Abinanthan.A²

¹Assistant Professor, Department of EEE, Narasu's Sarathy Institute of Technology, Tamil Nadu, India

²Students, Department of EEE, Narasu's Sarathy Institute of Technology, Tamil Nadu, India

ABSTRACT

Pulse width modulation (PWM) converters are frequently used due to unity power factor operation with reduced total harmonic distortion (THD) at ac mains and also provide constant-regulated dc output voltage even under fluctuations of ac voltage and dc load. This paper contains the harmonics analysis of sinusoidal PWM (SPWM) technique and space vector PWM (SVPWM) technique for three-phase AC to DC converters using MATLAB/SIMULINK software. In this paper simulation models for both techniques are simulated with closed loop at rated load condition and harmonics analysis has been done using FFT tool of simulink in MATLAB.

Keywords : Flexible AC Transmission System, Converter, ANN, SPWM, THD, SVPWM, VSR

I. INTRODUCTION

The rapid development of renewable generation boosted the need for efficient, cheap, and robust converters that would interface them to the grid, without compromising the quality of supply for the end user. Most renewables provide a dc source of electric power, thus proper interfacing to the grid requires at least an inverter. Often, due to the low voltage acquired from sources such as domestic wind turbines, solar arrays or fuel cells, a boost converter or/and a transformer (if isolation is required) is added at the dc or ac side, respectively, in order to boost the voltage to the appropriate level.

The most common type of commercial inverter used for this kind of applications is a variation of sinusoidal pulse width modulation full-bridge inverter. The simplicity of the design provides robust operation and

simple control, but the harmonic content of the output requires a low-pass filter to comply with the standards. Two disadvantages of this application are the increased size and cost due to the filter and the losses of the semiconducting switches performing the inverting operation at the inverter bridge (four) and the boost converter (one), usually, at a non-acoustic frequency. Several PWM methods have been developed in order to reduce the harmonic content. Normally the input voltage to an AC-to-DC converter is sinusoidal but the input current is non-sinusoidal i.e. harmonic currents are present in the ac lines. Harmonics have a negative effect on the operation of the electrical system and therefore, an increasing attention is paid to their generation and control.

Harmonics have a negative effect on the power factor as well. The addition of harmonic currents to the fundamental component increases the total rms

current hence harmonics will affect the power factor of the circuit. Unity power factor, lower harmonic current or low input current THD and fixed DC output voltage with minimum ripple are the important parameters in rectifier. A pulse width modulation (PWM) rectifier serves all these purposes, which operates in four quadrants with high power factor. The PWM is a very advance and useful technique in which width of the gate pulses are controlled by various mechanisms. PWM rectifiers shift the frequency of the dominant harmonics to a higher value, so that they can be easily filter harmonics by employing a small passive filter. The PWM rectifier is also known as active front end (AFE) converter. By using advance PWM control techniques such as sinusoidal PWM (SPWM) and space vector PWM (SVPWM). The Space Vector Pulse Width Modulation (SVPWM) refers to a special switching sequence of the upper three power devices of a three-phase voltage source inverters (VSI) used in application such as AC induction and permanent magnet synchronous motor drives. It is a more sophisticated technique for generating sine wave that provides a higher voltage to the motor with lower total harmonic distortion. Space Vector PWM (SVPWM) method is an advanced; computation intensive PWM method and possibly the best techniques for variable frequency drive application.

In SVPWM technique, instead of using a separate modulator for each of the three phases, the complex reference voltage vector is processed as a whole. Therefore, the interaction between the three motor phases is considered. SVPWM generates less harmonic distortion in the output voltages and currents in the windings of the motor load and provides a more efficient use of the DC supply voltage in comparison with sinusoidal modulation techniques. Since SVPWM provides a constant switching frequency; the switching frequency can be adjusted easily. Although SVPWM is more complicated than sinusoidal PWM, it may be implemented easily with modern DSP based control systems.

The modeling and simulation of a single phase AC to DC boost converter using MATLAB/SIMULINK has been presented. Active power factor corrector controls input current of load in such a way that current wave-form is proportional to supply voltage waveform. Hence, the power factor of boost converter will become nearer to unity, which can be clearly seen from the simulation results. Boost converter provides fixed DC voltage, even if input voltage is under certain variations. Thus it's an optimal converter in terms of performance, efficiency and provides unidirectional (DC) power flow in application such as power supplies; electronic ballast and low power drive applications. A single phase AC to DC boost converter with PID controller has been proposed. This method achieves Unity Power Factor and reduces the input line Harmonics which also maintain constant output voltage. The ultimate aim of the proposed method is to maintain the Power Factor above 0.95 and to reduce the Total Harmonic Distortion.

II. EXISTING METHOD

This existing method proposes a single power-conversion ac-dc converter with high power factor and high efficiency. The proposed converter is derived by integrating a full-bridge diode rectifier and a series-resonant active-clamp dc-dc converter. To obtain a high power factor without a power factor correction circuit, this paper proposes a novel control algorithm. The proposed converter provides single power-conversion by using the novel control algorithm for both power factor correction and output control. Also, the active-clamp circuit clamps the surge voltage of switches and recycles the energy stored in the leakage inductance of the transformer. Moreover, it provides zero-voltage turn-on switching of the switches. The operation principle of the converter is analyzed and verified.

Experimental results for a 400 W ac-dc converter at a constant switching frequency of 50 kHz are obtained

to show the performance of the This paper has proposed a single power-processing ac–dc converter with a high power factor and high power efficiency. Also, analysis, design, and experimental results for the proposed converter have been presented. The proposed converter combines the full-bridge diode rectifier and the series-resonant active-clamp dc–dc converter. The series-resonant active-clamp dc–dc converter is based on a flyback converter that employs the active-clamp at the transformer primary side and the voltage doubler at the transformer secondary side to reduce the switching losses and the voltage stress of the main switch suffered from the transformer leakage inductance. Also, the proposed converter provides a simple structure, a low cost, and low voltage stresses by the single power-conversion without a PFC circuit.

Therefore, the proposed converter is suitable for low-power applications for both PFC and power control. The proposed control algorithm can be used to the boost type PFC ac–dc converters since it is based on the control algorithm of the PFC boost converter in the continuous conduction mode. In view of this, the objective of this paper is to propose the single power-conversion ac–dc converter with the high power factor and the high power efficiency. The proposed converter is composed of a full-bridge diode rectifier and a series-resonant active-clamp dc–dc converter.

The proposed converter provides a simple structure, a low cost, and low voltage stresses because it has only high frequency dc–dc converter. To obtain high power factor without a PFC stage, a novel control algorithm is proposed. The proposed converter provides high power factor and single power-conversion by using the novel control algorithm instead of the PFC circuit. Also, the active-clamp circuit clamps the surge voltage of switches and recycles the energy stored in the leakage inductance of the transformer. Moreover, it provides ZVS operation of the switches. Also, a series-resonant circuit of the output-voltage doubler removes the

reverse-recovery problem of the output diodes by zero-current switching (ZCS) operation.

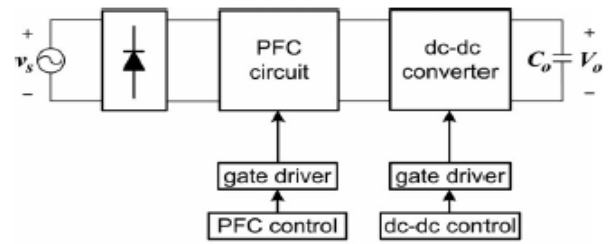

Fig. 1. Conventional block diagram

Disadvantages: The accuracy of the system is quite low due to the normal PWM technique. The control logic can't suitable for high level applications. However, the conventional single-stage ac–dc converters have high voltage stresses or a low power factor in comparison with the two-stage ac–dc converter. The PFC circuit used in the single-stage ac–dc converter requires the dc-link electrolytic capacitor and the inductor. The dc-link electrolytic capacitor and the inductor raise the size and the cost of the converter.

A proportional-integral-derivative controller (PID controller) is a control loop feedback mechanism (controller) widely used in industrial control systems. A PID controller calculates an error value as the difference between a measured process variable and a desired set point. The controller attempts to minimize the error by adjusting the process through use of a manipulated variable. The PID controller algorithm involves three separate constant parameters, and is accordingly sometimes called three-term control: the proportional, the integral and derivative values, denoted P, I, and D. Simply put, these values can be interpreted in terms of time: P depends on the present error, I on the accumulation of past errors, and D is a prediction of future errors, based on current rate of change.

The weighted sum of these three actions is used to adjust the process via a control element such as the position of a control valve, a damper, or the power supplied to a heating element. In the absence of knowledge of the underlying process, a PID

controller has historically been considered to be the best controller. By tuning the three parameters in the PID controller algorithm, the controller can provide control action designed for specific process requirements. The response of the controller can be described in terms of the responsiveness of the controller to an error, the degree to which the controller overshoots the set point, and the degree of system oscillation. Note that the use of the PID algorithm for control does not guarantee optimal control of the system or system stability. Some applications may require using only one or two actions to provide the appropriate system control. This is achieved by setting the other parameters to zero. A PID controller will be called a PI, PD, P or I controller in the absence of the respective control actions. PI controllers are fairly common, since derivative action is sensitive to measurement noise, whereas the absence of an integral term may prevent the system from reaching its target value due to the control action.

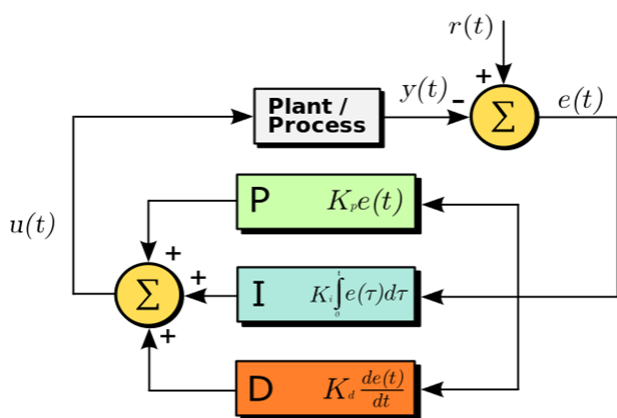

Fig.2 structure of PID

III. PROPOSED METHOD

A different approach to PWM modulation is based on the space vector representation.

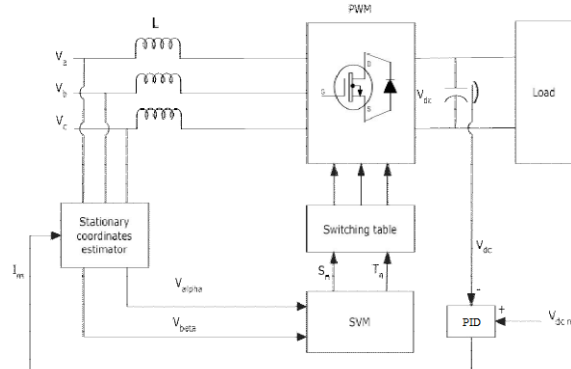

Fig. 3. Proposed block diagram

In SVPWM, the voltage reference is provided using a revolving reference vector and magnitude and frequency of the fundamental component in the line side are controlled by the magnitude and frequency of the reference voltage vector respectively. The space vector modulation (SVM) technique is an advanced, computation intensive digital PWM technique in which the objective is to generate PWM load line voltages that are on average equal to given load line voltages. This is done in each sampling period by properly selecting the switch states from the valid ones of VSR and by proper calculation of the period of times they are used. It is a more sophisticated technique for generating sine wave that provides a higher voltage to the motor with lower THD.

This block diagram has three main blocks, stationary coordinate's estimator, SVM signal generator and switching table. From the ac side three-phase currents (ia,ib,ic) converted to two-phase current ordinates (iα & iβ). Similarly, from the three-phase voltage converted to two-phase voltage ordinates and cosine values by using Clark's transformation. The current coordinate are changed to voltage cosines.

The controller consists of outer bus voltage regulation loop and inner phase current regulation loop. Actual bus feedback (Vdc) is compared with the desired bus voltage (Vdc ref) and the error is passed through a PID controller, the outer loop generates the amplitude of the reference current (Im). The stationary co-ordinates estimator block has two inputs (input supply and line current Im). The input current voltage vector coordinates is compare to input voltage

d-q coordinates and add with inductance drop. These d-q voltage vectors have converted to α - β coordinates. The stationary estimator estimates V_{α} and V_{β} . In SVM block, number of the instantaneous sector and the time T_1 , T_2 and T_0 are getting from the stationary coordinates V_{α} and V_{β} . The number of sector (S_n) and the required switching time (T_n) select instantaneous firing signal.

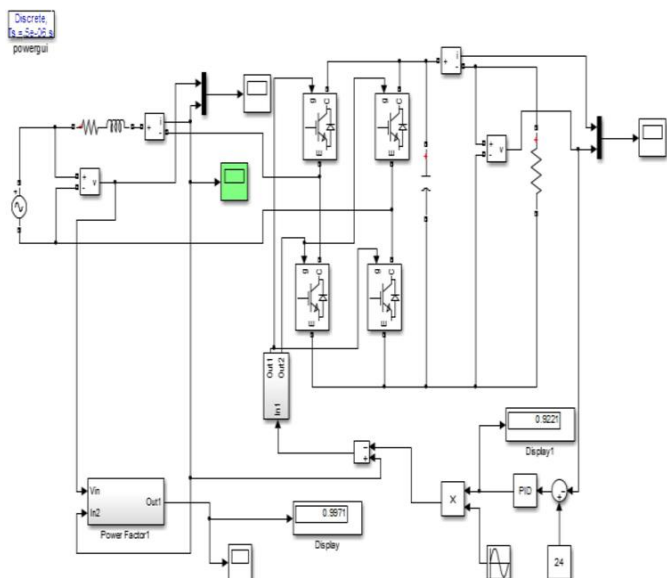

Fig.4. Simulation diagram

The main objective of the proposed method is to obtain a unity power factor and to obtain a constant DC output voltage. Boost converter with an active power factor method is used. Active PFC uses switching regulator technology to draw current from the power line proportional to input voltage. It consists of feedback loops to control input current and to regulate output voltage. Active PFC offers better THD and is significantly smaller and lighter than a passive PFC circuit.

A supply voltage of 12V and resistive load of 10 Ω is used to achieve a sinusoidal current. The input voltage 12V is boost up to 24V. Obtained boost up voltage is compared with desired voltage and PID controller is used to generate a sinusoidal pulse to switch IGBTs. This method is tested for various voltages and various loads.

An inverter is nowadays commonly used in variable speed AC motor drives to produce a variable, three

phase, AC output voltage from a constant DC voltage. Since AC voltage is defined by two characteristics, amplitude and frequency, it is essential to work out a strategy that permits control over both these quantities. Pulse width modulation (PWM) controls the average output voltage over a sufficiently small period, called switching period, by producing pulses of variable duty-cycle. Here, sufficiently small means that the switching period is small compared to the period of the desired output voltage so that the output voltage may be considered equal to the desired.

A classical example is the so-called sine-triangular PWM. A high frequency triangular wave, called the carrier wave, is compared to a sinusoidal signal representing the desired output, called the reference wave. Usually, ordinary signal generators produce these signals. Whenever the carrier wave is less than the reference, a comparator produces a high output signal, which turn the upper transistor in one leg of the inverter on and the lower switch off. In the other case the comparator sets the firing signal low, which turns the lower switch on and the upper switch off.

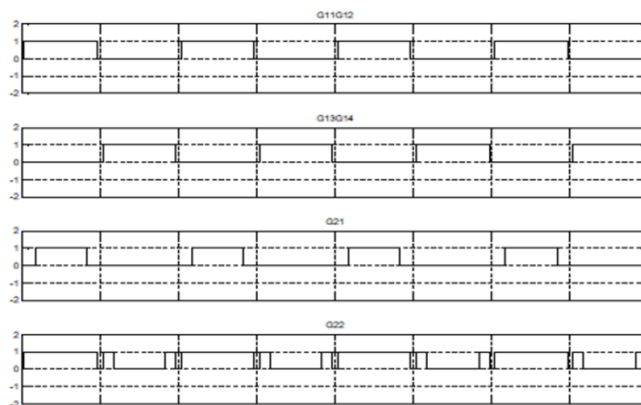

Fig. 5. Sine triangular PWM

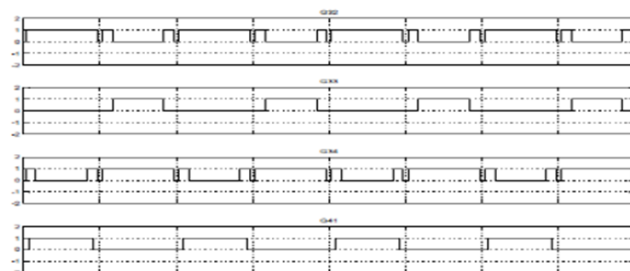

Fig. 6. PWM output signals for particular case with reference vector

With the use of low cost simple ON-OFF controller only two control states are possible, like fully ON or fully OFF. It is used for limited control application where these two control states are enough for control objective. However oscillating nature of this control limits its usage and hence it is being replaced by PID controllers.

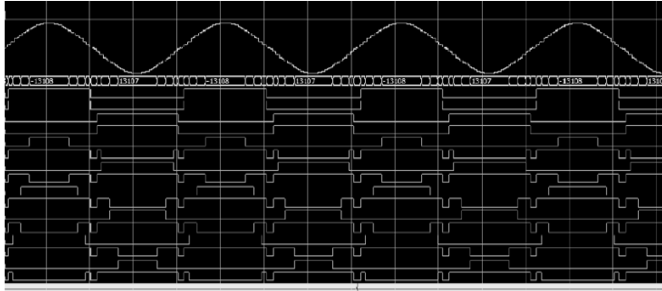

Fig.7. Gate Pulse (V) & Input Voltage (V) waveform of SPWM at rated load

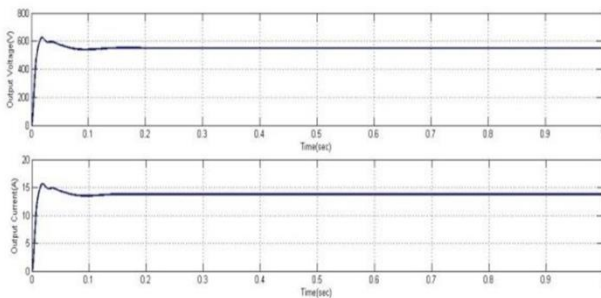

Fig.8. Output voltage (V) & output current (A) waveform of SPWM at rated load

Filtering Out Harmonics: Harmonics is becoming a crucial issue with the abrupt rise in the use of nonlinear loads these days. A Filter that removes these harmonics is one of the best solutions to this problem. This is done by injecting compensatory currents which counteract them at the Point where seclusion from non linearity of the load has to be provided. In order to infuse these Compensatory currents aptly, by the inverter within, it requires gating signals that trace the reference currents precisely which is provided by a controller. The reference currents are a measure of harmonics. Consequently, perfect calculation of these reference signals foster generation of proper gating signals for the inverter.

Accurate estimation is done using the P-Q theory, D-Q theory as well as the Adaline for Shunt and Hybrid Power Filter. DC Voltage across the capacitor is regulated using the PI controller and the ANN based control.

Advantages of Proposed method: Reduced fault current (stiff system). Distribution system impedance and distortion is low. Harmonic current draw is low Low fault current (soft system).

IV. FUTURE WORK

In future Power quality issues in related with voltage sag, voltage swell, compensation of reactive powers re to be studied using ANN and we have to investigate the generated output of converter using PI, Fuzzy and ANN to estimate the cost function .

V. CONCLUSION

The modeling and simulation of a single phase AC to DC boost converter using MATLAB/SIMULINK has been presented. Active power factor corrector controls input current of load in such a way that current wave-form is proportional to supply voltage waveform. Hence, the power factor of boost converter will become nearer to unity, which can be clearly seen from the simulation results. Boost converter provides fixed DC voltage, even if input voltage is under certain variations. Thus it's an optimal converter in terms of performance, efficiency and provides unidirectional (DC) power flow in application such as power supplies; electronic ballast and low power drive applications. A single phase AC to DC boost converter with PID controller has been proposed. This method achieves Unity Power Factor and reduces the input line Harmonics which also maintain constant output voltage. The ultimate aim of the proposed method is to maintain the Power Factor above 0.95 and to reduce the Total Harmonic

Distortion. The proposed method has been implemented in MATLAB.

VI. REFERENCES

- [1]. B. Singh, B. N. Singh, A. Chandra, K. Al-Haddad, A. Pandey, and D. P. Kothari, "A review of single-phase improved power quality AC-DC converters," *IEEE Trans. Ind. Electron.*
- [2]. B. Singh, B. N. Singh, A. Chandra, K. Al-Haddad, A. Pandey, and D. P. Kothari, "A review of three-phase improved power quality ac-dc converters," *IEEE Trans. Ind. Electron.*
- [3]. H. S. Kim, M. H. Ryu, J. W. Baek, and J. H. Jung, "High-efficiency isolated bidirectional AC-DC converter for a DC distribution system," *IEEE Trans. Power Electron.*
- [4]. M. Arias, D. G. Lamar, J. Sebastian, D. Balocco, and A. A. Diallo, "High efficiency LED driver without electrolytic capacitor for street lighting," *IEEE Trans. Ind. Appl.*
- [5]. Y. C. Li and C. L. Chen, "A novel single-stage high-power-factor ac-todc LED driving circuit with leakage inductance energy recycling," *IEEE Trans. Ind. Electron.*
- [6]. Y. Ji and Y. Xu, "Design and analysis of single-stage power factor correction converter with a feedback winding," *IEEE Trans. Power Electron.*
- [7]. D. D. C. Lu, H. H. C. Iu, and V. Pjevalica, "Single-stage ac/dc boostforward converter with high power and regulated bus and output voltage," *IEEE Trans. Ind. Electron.*
- [8]. T. H. Hsia, H. Y. Tsai, D. Chen, M. Lee, and C. S. Huang, "Interleaved active-clamping converter with ZVS/ZCS Features," *IEEE Trans. Power Electron.*
- [9]. T. F. Wu, J. C. Hung, S. Y. Tseng, and Y. M. Chen, "A single-stage fast regulator with PFC based on an asymmetrical half-bridge topology," *IEEE Trans. Ind. Electron.*
- [10]. M. Arias, M. F. Diaz, D. G. Lamar, D. Balocco, A. A. Diallo, and J. Sebastian, "High-efficiency asymmetrical half-bridge converter without electrolytic capacitor for low-output-voltage ac-dc LED drivers," *IEEE Trans. Power Electron.*